

WEIGHT FOR OPEN WLS

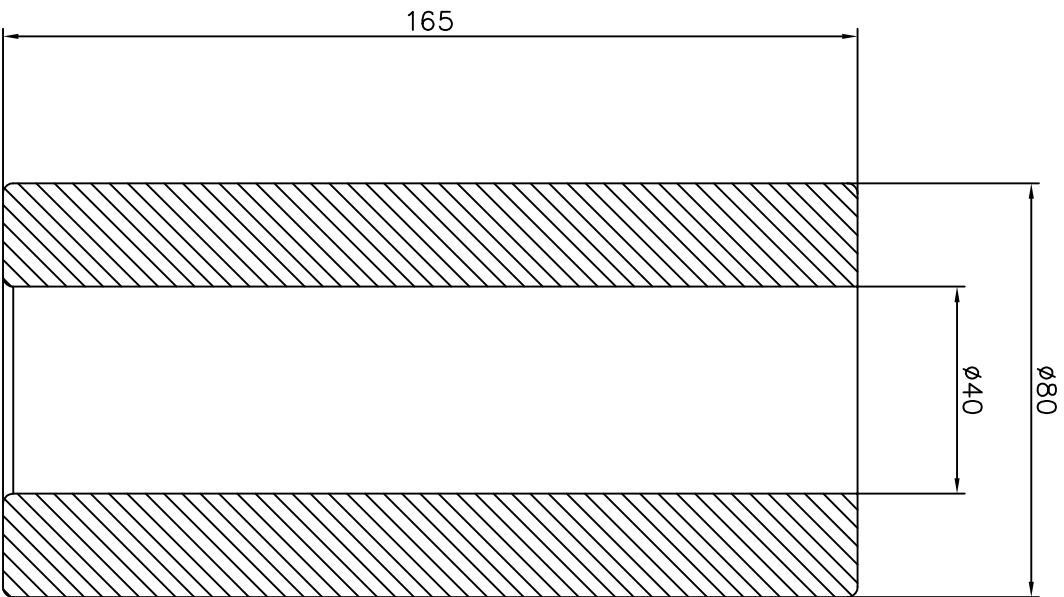

WEIGHT FOR CLOSED WLS

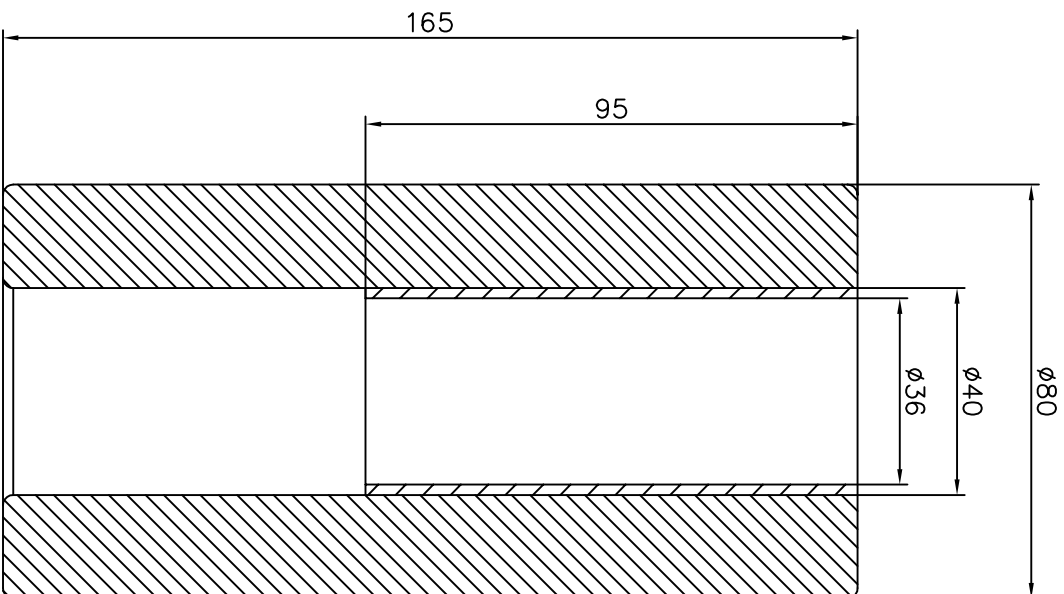

INSTALLATION OF TOP WEIGHT FOR WLS

1. The MST and WLS are welded together
2. The top weight has a diameter of 80mm or 3.15" and a weight of 5kg or 10Lb, stainless steel – AISI 304. This is the designed maximum weight when the sensor is in vertical position in the tank.
3. Mount the top weight before the sensor is lowered into the tank
4. Remove any locknuts or lockrings before the weight is carefully threaded on the top end and pulled down along the MST
5. When the top weight reaches the top of the WLS the larger diameter of this sensor prevents the top weight to go any further down
6. Make sure that the weight is in a stable position at its lowest position and lower the sensor and MST into the tank nozzle. Observe the weight position towards tankbottom

TOWARDS TANKBOTTOM

ISSUED BY	WEEK	PRODUCT CODE	TITLE	INSTALLATION DRAWING TITLE
GSP-AJ	0345	REX	ACAD	TOP WEIGHT FOR WLS
APPROVED BY	WEEK	ORIGINAL DWG NO.	SCALE	TOP WEIGHT FOR WLS
GSP	0345	9261 065-080	1:1	5KG
ROSEMOUNT		1 ST ANGLE	DOC TYPE	DWG NO.
Tank Gauging			2	9261 065-080
THE COMPANY ASSUMES NO RESPONSIBILITY FOR THE ACCURACY OF THIS DOCUMENT UNLESS IT IS SPECIFICALLY STATED OTHERWISE. THE COMPANY SHALL BE RESPONSIBLE FOR THE ACCURACY OF THIS DOCUMENT UNLESS IT IS SPECIFICALLY STATED OTHERWISE. THE COMPANY SHALL BE RESPONSIBLE FOR THE ACCURACY OF THIS DOCUMENT UNLESS IT IS SPECIFICALLY STATED OTHERWISE.				ISSUE
				SHEET
				1/1